

MARLBORO TOWNSHIP

DISCONNECT/RECONNECT

WATER SERVICE CONNECTION REQUIRED

DOCUMENT CHECKLIST

CONTACT INFORMATION:

NAME: _____

ADDRESS: _____

PHONE: _____

EMAIL: _____

COMPLETED APPLICATION

COLLECTOR SIGNED HOLD HARMLESS

AGREEMENT INSURANCE CERTIFICATE

WITH TOWNSHIP AS NAMED INSURED
(SEE SAMPLE)

PLUMBING SKETCH WITH CONNECTION
DETAILS SIGNED AND SEALED BY
PLUMBER

MARLBORO TOWNSHIP

Water Utility Division

1979 TOWNSHIP DRIVE, MARLBORO, NEW JERSEY 07746

Telephone No. (732) 536-0200 Ext. 1816

Fax No. (732) 591-0967

APPLICATION FOR WATER SERVICE:

CONNECTION – Please fill out Section I

DISCONNECTION – Permanently disconnecting from water system – Please fill out Section II

DISCONNECTION – Temporarily disconnecting from water system – with intention to reconnect in the future – Please fill out Sections I & II

I/We, the undersigned, as of ____/____/20____, are the sole and exclusive owner(s) of the premises known and designated as Block _____, Lot _____, on the official tax map of the Township of Marlboro, Monmouth County, New Jersey, more commonly known as _____, Marlboro Township, New

(street address)

Jersey.

Section I

I/We wish to receive water service from the Marlboro Township Water Utility Division and hereby make application to the Marlboro Township Water Utility Division for permission and approval to install or cause to be installed, strictly in accordance with Marlboro Township Water Utility Division's rules and regulations, the Uniform Construction Code and other applicable construction code requirements, a water service connection from the Marlboro Township Water Utility Division's water distribution system to the following dwelling, building, facility or other structure, equipment or the like and for no other purpose(s):

Description: () dwelling () building () facility, structure or other

(explain character and use of above designation)

Location: Street Address _____

Block _____ Lot _____

Distance in feet from curb to dwelling: _____

Water Meter: Size _____ Water Service/Use/Connection Fee* \$ _____

*See note below

*NOTE: The amount of the water service/use/connection fee set forth on the front page of this Application may change. The total amount of such water service/use/connection fee shall be finally determined as of the date that a connection is actually made into the Marlboro Township Water Utility Division's water system and a water meter is installed. You, as the applicant, shall be responsible for paying such finally determined amount in full. If you are on an installment

payment plan, your remaining principal balance shall be recalculated and the adjusted amount must be paid, in full, together with interest over the remaining life of the initial installment period.

The foregoing water service/use/connection fee has been paid prior to the submission of the within application or paid simultaneously therewith or the applicant is eligible and qualifies for payment of same on an installment basis and has executed an appropriate Installment Payment Agreement.

Section II

I/We wish to terminate water service from the Marlboro Township Water Utility Division and hereby make application to the Marlboro Township Water Utility Division for permission and approval to disconnect or cause to be disconnected, strictly in accordance with Marlboro Township Water Utility Division’s rules and regulations and other applicable construction code requirements, an existing water service connection from the Marlboro Township Water Utility Division’s water distribution system to the following dwelling, building, facility or other structure, equipment or the like:

Description: () dwelling () building () facility, structure or other

_____ (explain character and use of above designation)

Location: Street Address _____

It is understood and agreed that any person or company or other entity causing a water service connection to be installed an/or connected to the Marlboro Township Water Utility Division’s water distribution system or causing water service to be made available therefrom to any dwelling, building, facility or any other structure, equipment or the like, and any person, company or other entity who aids or assists in the installation of any such water service connection or causes water service to be made available, without having first obtained written approval therefore from the Marlboro Township Water Utility Division and having complied with all Marlboro Township Water Utility Division rules and regulations, including, but not necessarily limited to, the payment of all water service/use/connection fees, the execution of an appropriate water service agreement and the installation of an approved water meter shall be subject to a penalty of \$500.00 for the first offense, \$750.00 for a second offense and \$1,000.00 each for a third and subsequent offense (s) and, in addition thereto, the violator shall be subject to termination of water service and other remedies available to the Marlboro Township Water Utility Division pursuant to N.J.S.A. 40:14B-1 et seq.

DATED: _____ APPLICANT _____

APPLICANT _____

DENIED: Resubmit Application

APPROVED: The Marlboro Township Water Utility Division hereby approves and authorizes a water service connection to service the above described use via the above designated water meter and/or disconnection at the above location.

Authorized Agent/Officer

HOLD HARMLESS AND INDEMNIFICATION AGREEMENT

AGREEMENT made as of the _____ day of _____, _____

by and between

THE TOWNSHIP OF MARLBORO,
a municipal corporation of the State of New Jersey, situated in the County of Monmouth,

with its administrative office located at, and having a mailing address of, 1979 Township Drive, Marlboro, New Jersey 07746 (hereinafter referred to as the “Township”),

and

having a mailing address of _____, hereinafter referred to as the “Contractor”).

WITNESSETH:

WHEREAS, the **Township** owns and operates a Public Community Water System within the Township of Marlboro and provides water and water services for public and private uses within its service area; and

WHEREAS, _____, (hereinafter referred to as the "**Customer**") is the owner of certain real property located at _____, in the Township of Marlboro, County of Monmouth and State of New Jersey, which said lands are known and designated as Lots ___ & _____ in Block _____ on the Official Tax Map of said Township (hereinafter sometimes referred to as the "**Property**"); and

WHEREAS, with respect to the the **Property**, **Customer** proposes _____

all for the purpose of receiving water and water services from the **Township** relative to the aforementioned real property; and

WHEREAS, as part of **Customer's** proposed plans, it will be necessary for **Customer**, and his agents, servants, employees, contractors and/or subcontractors, and/or the agents, servants and employees of any such contractors and/or subcontractors, to perform and/or furnish certain work, labor, materials and/or services in, about, near and/or with respect to the **Township's** Water System or certain portions thereof; and

WHEREAS, **Customer** has specifically engaged the **Contractor** to install the water systems improvements referred to herein and contemplated hereby and to otherwise perform all requisite work to effectuate a water service connection between the **Township's** Water System and **Customer's Property** and residential dwelling situated thereon;

NOW, THEREFORE, in consideration of the mutual promises and covenants set forth herein and for other good and valuable consideration, it is hereby agreed as follows:

1. **Definitions.** As used throughout this Hold Harmless and Indemnification Agreement the term of word "**Contractor**" shall mean, " _____, and all agents, servants, employees, contractors and/or subcontractors employed or engaged by _____,

as well as all agents, servants and employees engaged by the respective contractors and/or subcontractors of _____."

2. With respect to all **work, labor, materials and/or services to be performed and undertaken by the Contractor** in, about, near and/or with respect to the **Township's Water System** or any portions thereof, **same shall be performed and completed strictly in accordance with all approvals or authorizations granted by the Township and/or as specifically and expressly directed by the personnel of the Township's Water Utility Division and in accordance with the Township's Rules and Regulations and applicable law.**

3. With respect to any and all trenches, road openings and/or other excavations made by and/or on behalf of the **Contractor**, the **Contractor** shall restore all disturbed areas and/or affected public rights-of-way to the same or as good condition as such areas and/or public rights-of-way were in prior to any such disturbance and/or the making of any such trenches, road openings and/or other excavations. Furthermore, the **Contractor** shall, to the extent applicable, restore the **Township's Water System**, and/or such portions thereof as relate to its construction, to the same or as good condition as said Water System was in prior to any such construction. The **Township's** Director of Public Works, Water Utility Division Supervisor, or the Licensed Operator of the Water System shall determine the extent, nature and scope of all restoration, which shall be effected to their reasonable satisfaction and approval.

4. With respect to all work, labor, materials and/or services to be performed, provided, furnished and/or undertaken by the **Contractor**, the **Contractor** shall indemnify and hold the **Township** harmless from, against and with respect to any and all loss, injury or damage arising out of or resulting from any and all work, labor, materials and/or services so performed, provided, furnished and/or undertaken. Moreover, the **Contractor** shall indemnify and hold the **Township** harmless from, against and with respect to any and all claims, demands, actions and judgments, including, but not necessarily limited to, any and all liability claims, property damage claims, personal injury claims, worker's compensation claims and products liability claims arising out of or resulting from any and all actions and/or inactions taken or failed to be taken by the **Contractor**, and

the **Contractor** shall defend any and all suits, claims or other actions which may be brought against the **Township** on account of any of the foregoing, and the **Contractor** shall make good to and reimburse the **Township** for any expenditures made or costs incurred by the said **Township** with respect to any of the foregoing, including any and all expenses for legal services.

5. In connection with the terms and provisions set forth in the preceding paragraph 4 and in order to provide the **Township** with additional protection against losses or damages, the **Contractor** shall cause the **Township** to be designated as an additional insured under the **Contractor's** general liability insurance policy or policies, including any excess liability (umbrella) policy. In that regard, this Agreement shall also be considered, for the purposes of insurance coverages, to be a **Work Contract, or similar agreement**, and the **Contractor's** obligation to provide insurance coverage for the **Township**, as an additional insured, is hereby made mandatory and shall relate to all of the **Contractor's** proposed or intended work and/or construction activities referred to in this Agreement with respect to the subject **Property**, including the installation of any water service connection(s). Prior to the commencement of any work and/or labor, or the furnishing of any services, equipment or materials, the **Contractor** shall provide the **Township** with an appropriate Certificate of Insurance, specifically naming the Township of Marlboro as an additional insured and evidencing **insurance coverage as follows:**

- A. Commercial General Liability \$3,000,000
- B. Automobile Liability-Owner, Non-Owner and Hired \$1,000,000
- C. Workers Compensation (Applicable to New Jersey State Statutes) Employers' Liability Statutory

The above insurance coverage must remain in effect until final written approval is issued by the Water Utility Division and, insurance certificates must provide for a thirty (30) day notice of any changes or cancellation.

6. This Agreement shall be binding upon the parties hereto and their respective heirs, successors and/or assigns.

IN WITNESS WHEREOF, the parties have signed this Agreement, and/or caused this Agreement to be signed by their proper corporate officers and to have caused their proper corporate seals to be affixed hereto, as of the day and year first above written.

Business Name of Contractor
Organized and existing under the laws of the State of New Jersey;

BY: _____
Signature

Printed Name & Title

ATTEST:

TOWNSHIP OF MARLBORO

ALIDA MANCO, Clerk

BY: _____
ROBERT MILLER, Superintendent of Public Works



CERTIFICATE OF LIABILITY INSURANCE

DATE (MM/DD/YYYY)
MONTH/DATE/YEAR

THIS CERTIFICATE IS ISSUED AS A MATTER OF INFORMATION ONLY AND CONFERS NO RIGHTS UPON THE CERTIFICATE HOLDER. THIS CERTIFICATE DOES NOT AFFIRMATIVELY OR NEGATIVELY AMEND, EXTEND OR ALTER THE COVERAGE AFFORDED BY THE POLICIES BELOW. THIS CERTIFICATE OF INSURANCE DOES NOT CONSTITUTE A CONTRACT BETWEEN THE ISSUING INSURER(S), AUTHORIZED REPRESENTATIVE OR PRODUCER, AND THE CERTIFICATE HOLDER.

IMPORTANT: If the certificate holder is an ADDITIONAL INSURED, the policy(ies) must be endorsed. If SUBROGATION IS WAIVED, subject to the terms and conditions of the policy, certain policies may require an endorsement. A statement on this certificate does not confer rights to the certificate holder in lieu of such endorsement(s).

PRODUCER INSURANCE AGENT/BROKER NAME ADDRESS	CONTACT NAME: INSURANCE AGENT/BROKER CONTACT
	PHONE (A/C, No, Ext): FAX (A/C, No): E-MAIL ADDRESS:
INSURED NAMED INSURED ADDRESS	INSURER(S) AFFORDING COVERAGE
	INSURER A: NAME OF INSURANCE COMPANY
	INSURER B:
	INSURER C:
	INSURER D:
	INSURER E:
	INSURER F:
	NAIC #
	#

COVERAGES CERTIFICATE NUMBER: RÉVISION NUMBER:

THIS IS TO CERTIFY THAT THE POLICIES OF INSURANCE LISTED BELOW HAVE BEEN ISSUED TO THE INSURED NAMED ABOVE FOR THE POLICY PERIOD INDICATED. NOTWITHSTANDING ANY REQUIREMENT, TERM OR CONDITION OF ANY CONTRACT OR OTHER DOCUMENT WITH RESPECT TO WHICH THIS CERTIFICATE MAY BE ISSUED OR MAY PERTAIN, THE INSURANCE AFFORDED BY THE POLICIES DESCRIBED HEREIN IS SUBJECT TO ALL THE TERMS, EXCLUSIONS AND CONDITIONS OF SUCH POLICIES. LIMITS SHOWN MAY HAVE BEEN REDUCED BY PAID CLAIMS.

INSR LTR	TYPE OF INSURANCE	ADDL INSD	SUBR WVD	POLICY NUMBER	POLICY EFF. (MM/DD/YYYY)	POLICY EXP. (MM/DD/YYYY)	LIMITS
A	<input checked="" type="checkbox"/> COMMERCIAL GENERAL LIABILITY <input type="checkbox"/> CLAIMS-MADE <input checked="" type="checkbox"/> OCCUR GENT. AGGREGATE LIMIT APPLIES PER: <input type="checkbox"/> POLICY <input type="checkbox"/> PRO-JECT <input type="checkbox"/> LOC OTHER:	X		XXXXX	XXXX	XXXX	EACH OCCURRENCE \$ 1,000,000 DAMAGE TO RENTED PREMISES (Ea occurrence) \$ MED EXP (Any one person) \$ PERSONAL & ADV INJURY \$ GENERAL AGGREGATE \$ 3,000,000 PRODUCTS - COMP/OP AGG \$ \$
A	AUTOMOBILE LIABILITY <input checked="" type="checkbox"/> ANY AUTO <input checked="" type="checkbox"/> ALL OWNED AUTOS <input type="checkbox"/> SCHEDULED AUTOS <input type="checkbox"/> HIRED AUTOS <input type="checkbox"/> NON-OWNED AUTOS			XXXXX	XXXX	XXXX	COMBINED SINGLE LIMIT (Ea accident) \$ 1,000,000 BODILY INJURY (Per person) \$ BODILY INJURY (Per accident) \$ PROPERTY DAMAGE (Per accident) \$ \$
	UMBRELLA LIAB <input type="checkbox"/> OCCUR EXCESS LIAB <input type="checkbox"/> CLAIMS-MADE DEO RETENTION \$			if applicable			EACH OCCURRENCE \$ AGGREGATE \$ \$
X	WORKERS COMPENSATION AND EMPLOYERS' LIABILITY ANY PROPRIETOR/PARTNER/EXECUTIVE OFFICER/MEMBER EXCLUDED? (Mandatory in NH) If yes, describe under DESCRIPTION OF OPERATIONS below	Y/N	N/A	XXXXX	XXXX	XXXX	<input checked="" type="checkbox"/> PER STATUTE <input type="checkbox"/> OTH-ER E.L. EACH ACCIDENT \$ 1,000,000 E.L. DISEASE - EA EMPLOYEE \$ 1,000,000 E.L. DISEASE - POLICY LIMIT \$ 1,000,000
	OTHER COVERAGES WHERE APPLICABLE						

DESCRIPTION OF OPERATIONS / LOCATIONS / VEHICLES (ACORD 101, Additional Remarks Schedule, may be attached if more space is required)

The Township of Marlboro, officers, employees, agents and servants are named as additional insured as their interests may appear in regards to _____ . The insurance listed herein is primary and on a non-contributory basis.

CERTIFICATE HOLDER Township of Marlboro 1979 Township Drive Marlboro, NJ 07746	CANCELLATION SHOULD ANY OF THE ABOVE DESCRIBED POLICIES BE CANCELLED BEFORE THE EXPIRATION DATE THEREOF, NOTICE WILL BE DELIVERED IN ACCORDANCE WITH THE POLICY PROVISIONS.
	AUTHORIZED REPRESENTATIVE MUST BE SIGNED

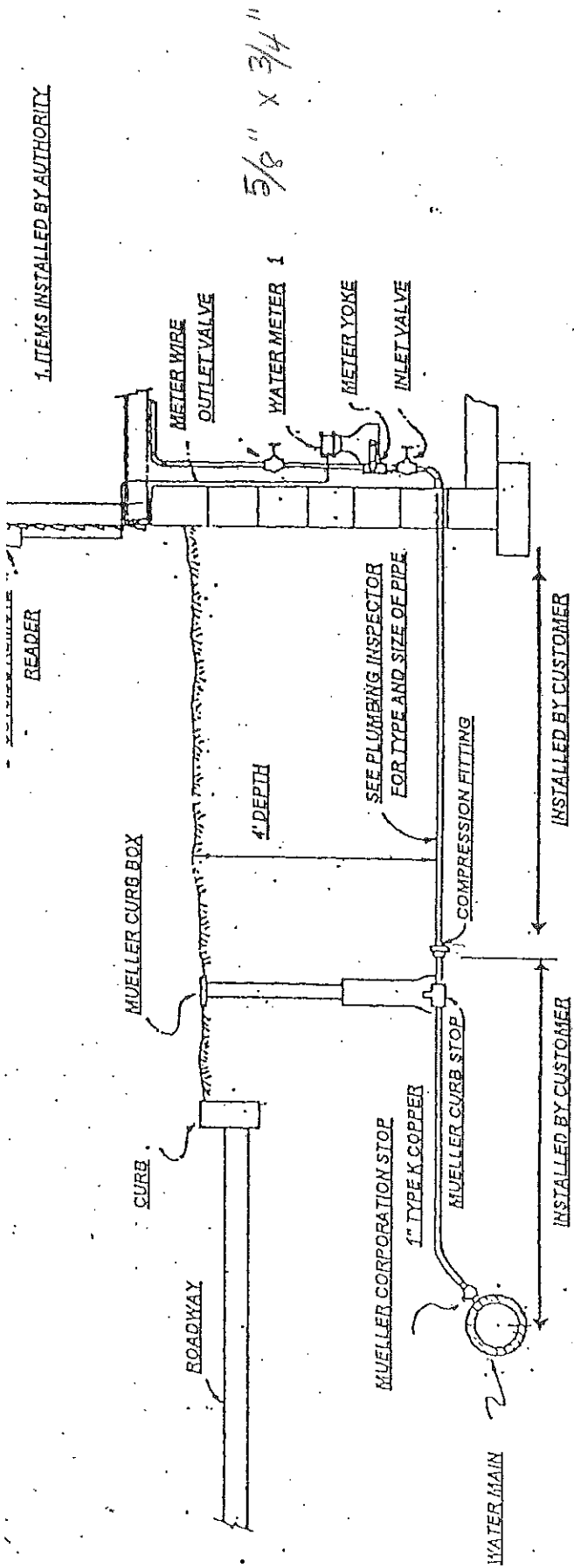

1. ITEMS INSTALLED BY AUTHORITY

5/8" x 3/4"

SERVICE CONNECTION

- * METER READOUT WIRE #22 AWG 3 CONDUCTOR SOLID COPPER
- * PRESSURE REDUCER MAY BE REQUIRED SEE PLUMBING INSPECTOR
- ** SLAB HOLES REQUIRE CONDUIT FOR METER WIRE TO OUTSIDE FRONT CORNER OF HOME

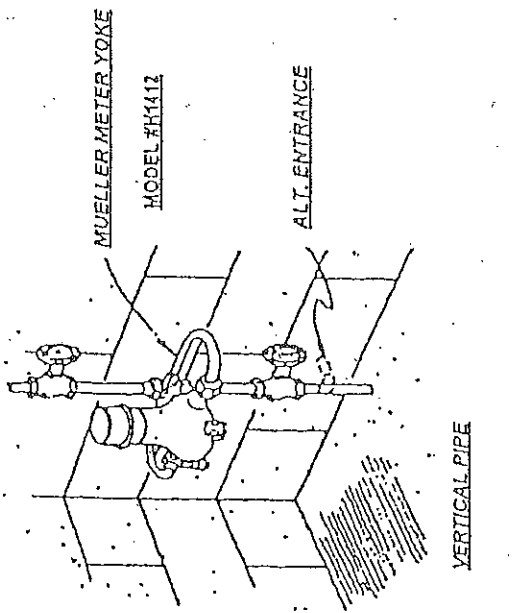

CORNER TYPE SETTING

METER SETTINGS

MARLBORO TOWNSHIP MUNICIPAL UTILITIES AUTHORITY

THE MARLBORO TOWNSHIP MUNICIPAL UTILITIES AUTHORITY
P.O. BOX 280
WICKATUNK, NJ 07765

STANDARD WATER DISTRIBUTION PRODUCTS

<u>NO.</u>	<u>ITEM</u>	<u>DESCRIPTION</u>	<u>MUELLER MODEL NO.</u>
1	Pipe & Fittings	Class 52 Ductile Iron Cement Lined (Double Thickness) U.S. Pipe Tyton Joint with FIELDLOK Gasket (U.S. Pipe or equal). Fittings shall be mechanical joint with retainer glands (Ebaa Iron Series 1100 mega lugs)	N/A
2	Fire Hydrants	AWWA C-502 Mueller Centurion Three Way (1) 4 1/2" dia. (2) 2 1/2" dia. outlets	A-423
3	Service Pipe	Soft Type "K" Copper ASTM B-88	N/A
4	Gate Valves (12" dia. & less) AWWA C-509	Resilient Seat Gate Valve NRS	A-2360-20 (MJ) A-2360-6 (F)
5	Valve Boxes	5 1/4" shaft, 2 piece Bingham & Taylor Fig. No. 4908 or Tyler Pipe	Bingham & Taylor Fig. 4908 or Tyler Pipe
6	Corporation Stops (Ball Design) min. 200 psi	Suitable for "K" Copper Service Pipe & 200 psi	H-25000 (Copper) H-25010 (Copper) H-25020 (Copper) or 110 (for plastic or copper tubing)
7	Curb Stops (Ball Design) Min. 200 psi	Inverted Key Stop Round way Suitable for "K" Copper Service Pipe	H-25204
8	Curb Boxes	With Stationary Rods	H-10314
9	Inside Meter Yokes	Vertical Inlet & Outlet Straight Line	H-1412, H-14168 or H1413
10	Outside Meter Pits	Coil Meter Box Mueller/McCulloch for 5/8" diameter by 3/4" meter	N/A
11	Tapping Sleeve & Tapping Valve	Ductile Iron Type	a. H-615 (sleeve) for D.I.P. b. H-687 (valve) c. H-619 (sleeve) for A.C. Pipe (12" dia. or less) d. Smith-Blair Model 663 Stainless steel sleeve w/ 304 s.s nuts & bolts for A.C. Pipe (16" dia. larger)
12	Butterfly (Larger than 12" dia.)	Mueller Line seal III AWWA C-504	B-3211-20

COPPER METER YOKES - CORNER TYPE WITH VERTICAL INLET AND OUTLET

Rev. 8-04

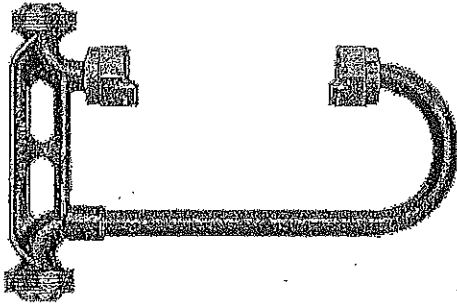

Multi-purpose thread ends
(H-1413 shown)

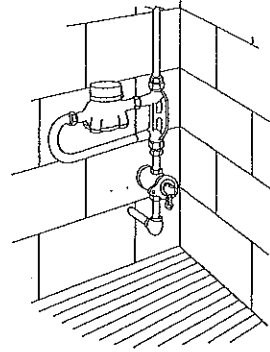

Typical installation of a corner type copper meter yoke with vertical inlet and outlet

Copper meter yokes - corner type with vertical inlet and outlet, and Multi-purpose thread ends

Catalog number	H-1413
Description	Plain yoke

Dimensions

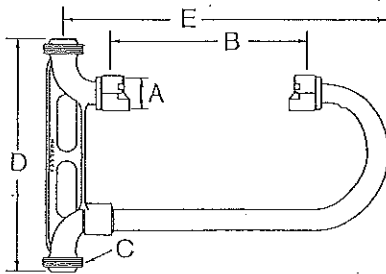

Meter size	5/8"	5/8" x 3/4"
Nominal size of I.P. thread in meter nut	3/4"	1"
Dimension A	1-1/16"	1-5/16"
Dimension B	7-7/8"	7-7/8"
Dimension C - nominal pipe size of inlet and outlet	3/4"	3/4"
Dimension D	8-5/16"	8-5/16"
Dimension E	13-1/16"	13-1/2"

Copper Meter Yokes are normally supplied less end connections. See pages 8A.41 and 8A.42 for end connections that can be used with these yokes.

SPECIFY METER SIZE AND CATALOG NUMBER.

COPPER METER YOKES - BASEMENT TYPE WITH VERTICAL INLET AND OUTLET

Mueller Co.

8A.25

Rev. 8-04

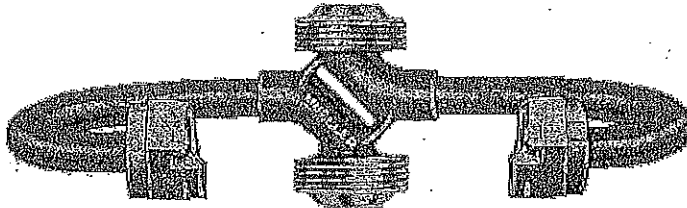

Multi-purpose thread ends

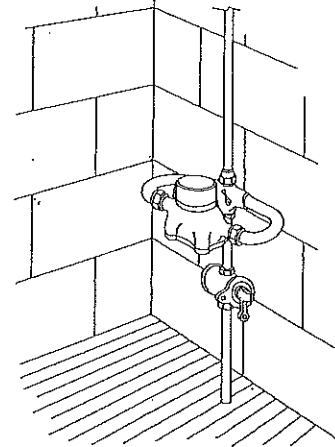

H-1412 shown.
Typical installation of a basement type copper meter yoke with vertical inlet and outlet

Copper meter yokes - basement type with vertical inlet and outlet, and multi-purpose thread ends

Catalog number	H-1412	H-1420
Description	Plain yoke	Offset plain yoke

Dimensions

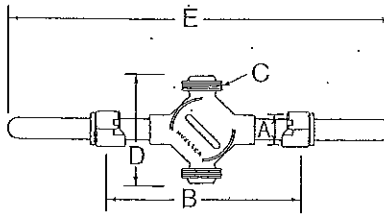

Meter size	5/8"	5/8" x 3/4"	3/4"	1"
Nominal size of I.P. thread in meter nut	3/4"	1"	1"	1-1/4"
Dimension A	1-1/16"	1-5/16"	1-5/16"	1-5/8"
Dimension B	7-7/8"	7-7/8"	9-3/8"	11-1/8"
Dimension C - nominal pipe size of inlet and outlet	3/4"	3/4"	3/4"	1"
Dimension D	3-11/16"	3-11/16"	4"	4-11/16"
Dimension E	13-3/4"	13-3/4"	16"	18-11/16"
Dimension F	5"	5"	6-1/4"	7-1/2"

Copper Meter Yokes are normally supplied less end connections. See pages 8A.41 and 8A.42 for end connections that can be used with these yokes.

SPECIFY METER SIZE AND CATALOG NUMBER.

COPPER METER YOKES WITH STRAIGHT LINE INLET AND OUTLET

Mueller Co. **8A.21**

Rev. 8-04

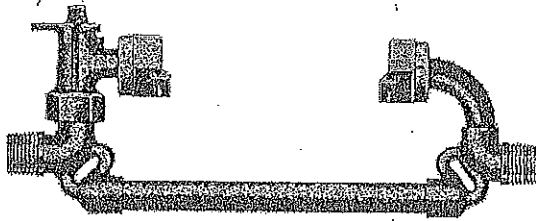

M.I.P. thread ends
(H-14180 shown)

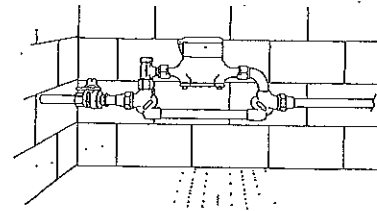

Typical installation of a straight line inlet and outlet copper meter yoke

Copper meter yokes with straight line inlet and outlet, and M.I.P. thread ends

Catalog number	H-14168	H-14171	H-14180	H-14183	B-24180	B-24183
Description	Plain yoke	With test valve	With lock wing ground key angle meter stop	With lock wing ground key angle meter stop and test valve	With lock wing MUELLER 300™ Angle Meter Ball Valve*	With lock wing MUELLER 300 Angle Ball Valve* and test valve

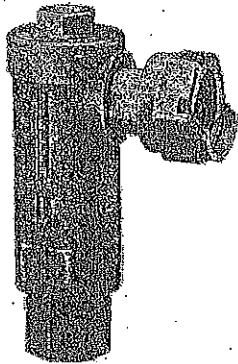

M-98™ ASSE approved top entry vertical check valve

Check valve options

MUELLER Copper Meter Yokes can be ordered with one of the following: an ASSE approved top entry vertical check valve; an ASSE approved dual check valve; a dual check valve (ASSE non-approved). To order the ASSE approved top entry check feature, add a suffix of -6A to the yoke catalog number; add -6D for the same check with a test drain. For the dual check feature, add a suffix of -2A to the yoke catalog number for the ASSE approved model or -2 suffix for the non-approved model. Examples: H-14180-6D for the ASSE approved top entry vertical check with a test drain; H-14180-2A for the ASSE approved model angle dual check valve.

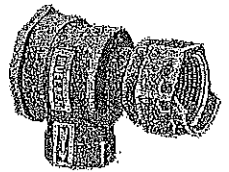

Angle dual check valve

Dimensions

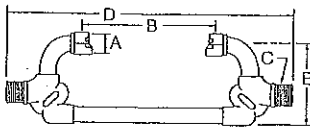

Meter size	5/8" **	5/8" x 3/4" **	3/4" **
Nominal size of I.P. thread in meter nut	3/4"	1"	1"
Dimension A	1-1/16"	1-5/16"	1-5/16"
Dimension B	7-7/8"	7-7/8"	9-3/8"
Dimension C - nominal pipe size of inlet and outlet	3/4"	3/4"	3/4"
Dimension D	14-1/16"	14-1/16"	15-9/16"
Dimension E	4-9/16" (7" **)	4-9/16" (7" **)	4-9/16" (7" **)

* Add "R" to the end of the yoke catalog number to order a reduced port Angle Ball Valve; EXAMPLE: 5/8x3/4x7 B-24180R.

** With 6A or 6D option.

Copper Meter Yokes are normally supplied less end connections. See section six (6) for end connections that can be used with these yokes.

SPECIFY METER SIZE AND CATALOG NUMBER.